



U-DISC 6-BOLT UNITIZED SPACER DISC COUPLING



THE U-DISC

U-DISC 6-BOLT UNITIZED SPACER DISC COUPLING

- U-DISC Same Day Shipping
- U-DISC Stocked in Two Convenient Locations
- U-DISC Simple 3-Piece Spacer Disc Coupling
- U-DISC Factory Pre-Assembled Spacer Disc Packs
- U-DISC Improved Reliability
- U-DISC Reduced Downtime
- U-DISC Infinite Life*
- U-DISC Lower Overall Cost
- U-DISC Power Dense and Torsionally Rigid
- U-DISC Complies with API-610 standard
- U-DISC Simple Inspection While in Operation
- U-DISC Lubrication and Maintenance FREE
- U-DISC Backlash FREE with No Wearing Parts
- U-DISC Well suited for Harsh Environments
- U-DISC AISI 301 Stainless Steel Disc Packs
- U-DISC Accommodates Angular and Parallel Misalignment

**When properly sized and aligned.*



WWW.U-DISC.COM

U-DISC

800-299-5104

U-DISC COUPLING INNOVATION

ENGINEERED FOR INFINITE LIFE - IMPROVED RELIABILITY - REDUCED DOWNTIME

The U-DISC coupling offers industry leading torque capacity and 1.5 degree misalignment capability resulting in infinite life when properly sized and aligned.

Disc couplings have become the preferred design for pumping and compressor applications used in the oil and gas industry due to their high torque, speed, misalignment, and maintenance free features. The advantages of the disc style coupling have also driven the API 610 specification.

The U-DISC 6 bolt drop IN unitized spacer disc coupling allows customers to save money by downsizing with a large hub option while meeting all the horsepower and torque requirements of the application.

The U-DISC coupling also helps prevent unexpected downtime costs by allowing inspection during operation. This is accomplished using a strobe light during operation and meets safety procedures. (Refer to page 7 for more on Strobe Light Inspection)

U-DISC coupling metric and imperial ratings*

Coupling style	Size range	Max torque*		Power per 100 RPM*		Max speed*	Max bore		Misalignment capability (Angular)	Misalignment capability (Parallel)	
		In-lbs.	Nm	HP/100	kW/100		Inch	mm		Inch	mm
Disc (Standard)	115-210	40,713	4,600	64.60	48.17	7,200/18,000**	5.315	135	1° - 1.5°	0.150	3.8

*Listed values represent the range of the entire product line. Ratings listed are the maximum ratings within the 115 to 210 coupling range. Ratings are dependent upon coupling size.

**Balanced



WWW.U-DISC.COM



800-299-5104



GUARANTEED
MAXIMIZED UPTIME
MINIMIZED MAINTENANCE
SAME DAY SHIPPING

MULTIPLE SIZES AVAILABLE

WWW.U-DISC.COM



800-299-5104

PAGE 3

OIL & GAS INDUSTRY FOCUS

API 610 DESIGN

The oil and gas industry demands performance, reliability, and uptime. As a result, API-the American Petroleum Institute, has developed the API-610 specification as the standard for pumping applications across the industry.

All U-DISC couplings can meet the API-610 specifications which include:

- *All metal flexible element spacer type couplings shall be manufactured in accordance with AGMA9000 class 9*
U-DISC couplings comply with AGMA9000 Class 9 specifications
- *Flexible elements shall be of corrosion-resistant material*
U-DISC coupling design integrates flexible discs made of corrosion resistant AISI-301 stainless steel
- *Couplings shall be designed to positively retain the spacer if a flexible element ruptures*
U-DISC coupling has a pilot machined in the coupling hubs which positively retains the spacer center assembly, preventing the center assembly from rotating free if a catastrophic bolt failure were to occur during operation. This ANTI-FLAIL feature is mandatory to API-610
- *Coupling hubs shall be steel*
U-DISC coupling hubs are 1045 steel
- *Couplings shall be capable of operation at 3800rpm*
U-DISC couplings are balanced and capable of operating at 3800rpm

Figure 1: U-DISC Coupling Configuration

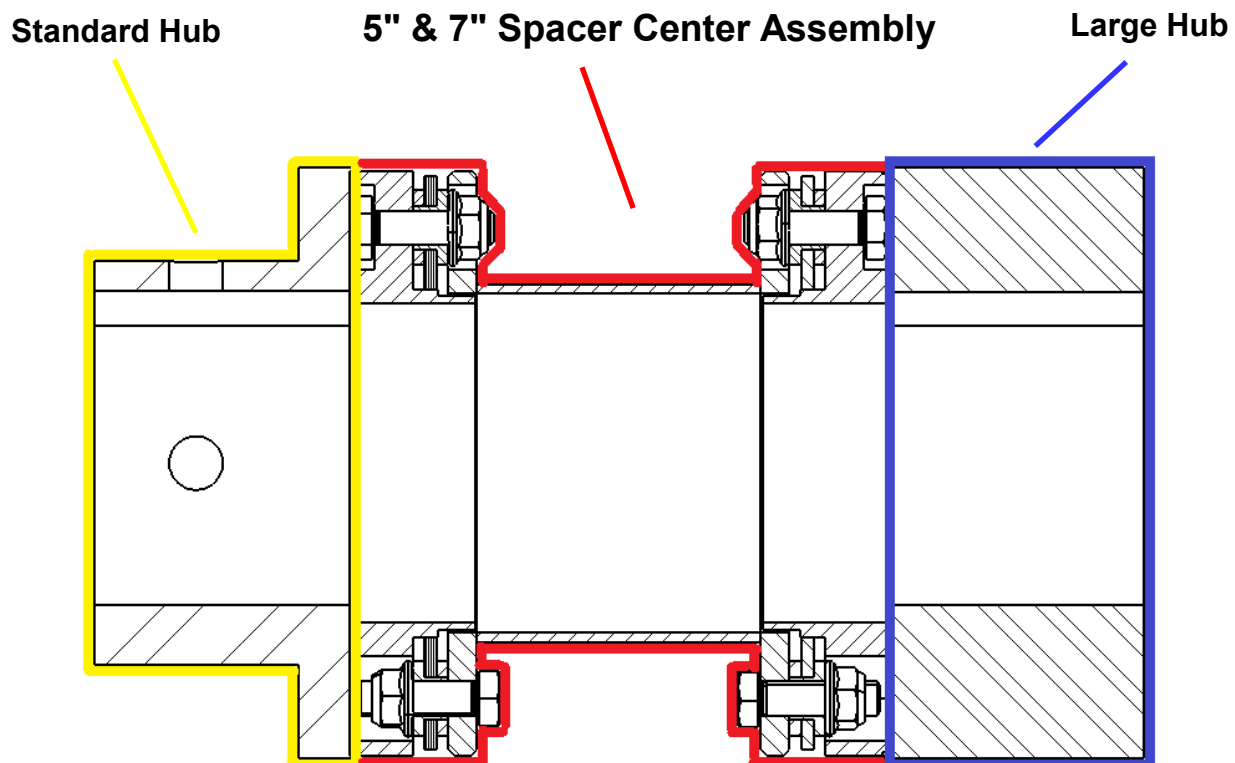

Piloted connections between spacer center assembly and shaft hubs allow the spacer center assembly to be positively retained during operation.

INFINITE LIFE* - IMPROVED RELIABILITY - REDUCED DOWNTIME

U-DISC GEOMETRY

The U-DISC coupling utilizes the newest generation of disc geometry, the dual scalloped design, which offers an even distribution of material along the axis of bolt center. Using FEA (Finite Element Analysis) Figure 2 allows visibility of the number of high stress areas within the disc to be limited to only a small area around the bolt hole. The improved DUAL SCALLOPED DESIGN geometry delivers 13% less peak stress than competitor's designs. This results in an average of DOUBLE the torque capacity. The even distribution of material along the axis of bolt center maximizes the ability of the U-DISC to handle misalignment and offers three times the misalignment capacity of competitors. Industry leading torque ratings and misalignment capabilities lead to longer life, improved reliability and reduced downtime.

Figure 2: U-DISC Geometry—Dual Scalloped Design

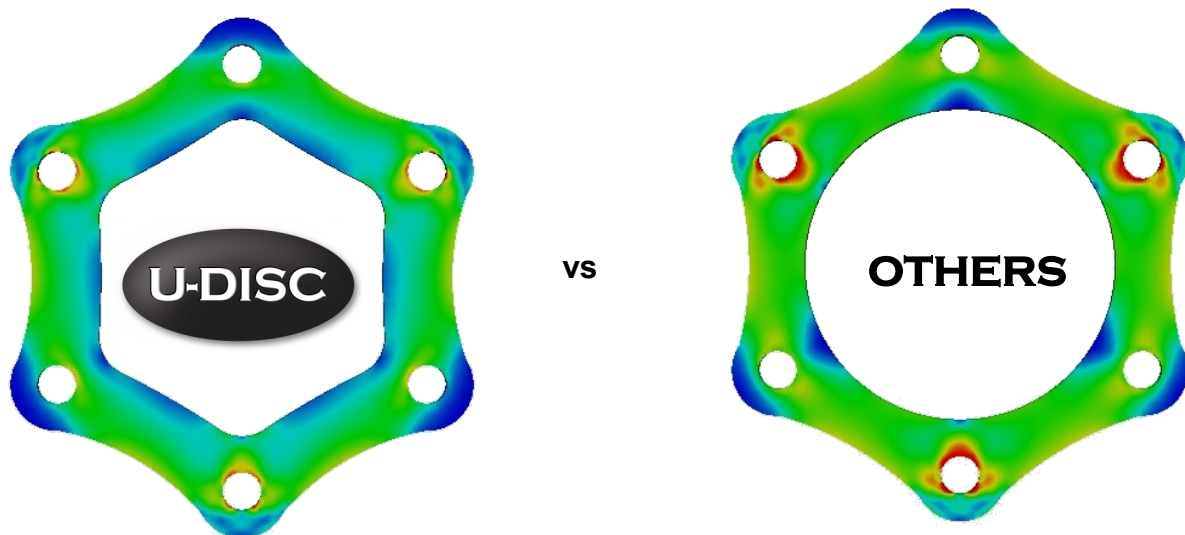

UNITIZED FACTORY PRE-ASSEMBLED DESIGN

U-DISC coupling spacer center assemblies include a spacer, two disc packs, and two guard rings. The coupling spacer center assemblies are pre-assembled at the factory to ensure that the system is assembled with the required tolerances and torque settings.

It also allows simplicity when ordering spare parts. The customer may order a single part number and receive a single unit-guaranteed to have the precise tolerances every time!

The factory assembled, unitized center assembly prevents any single component from transmitting the torque alone. Competitive designs ship loose discs for the end user to assemble. This increases the risk of improper installation which can reduce the life of the coupling.

The unitized, factory assembled drop in spacer assembly is just another reason the U-DISC coupling offers higher torque ratings, increased misalignment capacity and infinite life!*

**When properly sized and aligned.*

BEST OF BOTH COUPLING WORLDS

MAINTENANCE FREE

The U-DISC coupling offers the power density, large bore capacity, and high speed capabilities of a metallic coupling. The U-DISC coupling also eliminates the need for maintenance, as with the elastomeric couplings.

Traditional gear and grid style couplings require additional grease multiple times per year in order to lubricate gear teeth and looping segments.

However, the U-DISC coupling does not have relative movement between mating parts which allows for increased maintenance productivity and reduced unplanned downtime.

Additionally, by not having any moving components, the U-DISC coupling is torsionally rigid, prevents backlash, and is perfect for applications needing precise positioning such as paper machines.

POWER DENSE

Even when comparing the U-DISC coupling with an elastomeric design, the customer must sacrifice space since the maintenance free elastomeric option would be much larger to handle the required horsepower and torque.

Table 1 lists three common application examples driven by NEMA and IEC motors.

Table 2 reveals that the U-DISC coupling selection has a smaller outside diameter than the grid and gear couplings.

The U-DISC coupling selection has equal angular misalignment to the gear coupling and more than the grid coupling and is truly a power dense, maintenance free coupling that has infinite life when properly sized and aligned.

Table 1: Application Details for Metallic Coupling Comparison

	Application 1		Application 2		Application 3	
	NEMA	IEC	NEMA	IEC	NEMA	IEC
Motor Frame Size	256T	160	365T	250	445T	315
Motor Shaft Size	1 5/8"	42 mm	2 3/8"	65 mm	3 3/8"	80 mm
HP / kW	20 HP	15 kW	75 HP	55 kW	150 HP	110 kW
RPM	1750	1500	1750	1500	1750	1500
Service Factor	2.0	2.0	2.0	3.0	2.0	4.0
Torque	1,441 in-lbs	191 N-m	5,402 in-lbs	1,051 N-m	10,804 in-lbs	2,801 N-m

Table 2: Coupling Size Details for Metallic Coupling Comparison

		Application 1			Application 2			Application 3		
		Outside Diameter (inch)	Outside Diameter (mm)	Angular Misalignment	Outside Diameter (inch)	Outside Diameter (mm)	Angular Misalignment	Outside Diameter (inch)	Outside Diameter (mm)	Angular Misalignment
U-DISC Coupling	NEMA Motor	3.70	94.00	1.5°	5.47	139.00	1.5°	7.59	193.00	1.5°
	IEC Motor	3.70	94.00	1.5°	5.47	139.00	1.5°	7.59	193.00	1.5°
Gear Coupling	NEMA Motor	4.56	115.82	1.5°	7.00	177.80	1.5°	9.44	239.78	1.5°
	IEC Motor	6.00	152.40	1.5°	7.00	177.80	1.5°	9.44	239.78	1.5°
Grid Coupling	NEMA Motor	4.22	107.19	0.5°	5.92	2336.80	0.5°	7.70	195.58	0.5°
	IEC Motor	5.09	129.29	0.5°	6.92	175.77	0.5°	7.70	195.58	0.5°

LOWER COST, REDUCED DOWNTIME

DOWNIZING CAPABILITY

The U-DISC coupling not only offers a standard hub, but also a large hub to use in applications in which the coupling size is dictated by the bore size instead of torque.

The large hub offers a larger max bore than the standard hub, which allows the customer to save money by downsizing the coupling where applicable.

The U-DISC coupling can be ordered with either one or two large hubs.

Figure 3 : Large Hub and Standard Hub Configuration



REDUCE UNEXPECTED DOWNTIME WITH STROBE LIGHT INSPECTION

The U-DISC coupling has the ability to be inspected during operation. By observing the disc pack under a strobe light during operation, users can diagnose potential application issues before they experience costly, unexpected downtime.

Cracks in the discs clearly communicate to the user that the driver and driven shafts are severely misaligned. Also, an “S” condition, or buckling of a disc leg between the driver and driven connecting bolts, tells the user the application is experiencing a torque overload situation.

With this information, modifications can be made to the application to extend the life of the coupling or the spacer center assembly can be changed out, depending on the severity of the deformation.

INCREASED PRODUCTIVITY

SELECTION PROCEDURE

1. Select the driven machine service factor (SF_A) from Table 3.
2. Select the driving machine service factor (SF_D) from Table 4.
3. Add SF_A to SF_D to establish the combined service factor (SF).
4. Calculate the minimum torque rating:

$$T \text{ (in-lbs.)} = \frac{\text{HP} \times 63025 \times \text{SF}}{\text{RPM}}$$

5. Select coupling size from Table 5 with nominal torque capacity same or higher than calculated minimum torque rating.
6. Ensure peak torque of your application is below the coupling max. torque.
7. If coupling will be operated at speeds above 3800 rpm, dynamic balancing of the coupling may be considered.

Table 3

Driven Equipment	SF _A
BLOWERS , FANS	
Centrifugal	1.00
Lobe / Vane / Turboblowsers	1.25
Forced draught fans	1.50
Induc. draught with damper	1.50
Induc. draught without control	2.00
Cooling towers	2.00
CHEMICAL INDUSTRY	
Agitators (thin liquid)	1.00
Agitators (viscous liquid)	1.50
Centrifuges (light)	1.25
Centrifuges (heavy)	1.75
Mixers	1.75
COMPRESSORS	
Centrifugal	1.00
Lobe / Rotary	1.25
Turbocompressors	1.75
Reciprocating :	
1 to 3 cylinders	3.00
4 or more cylinders	1.75
CONVEYOR, HOISTS , ELEVATORS Note 1	
Conveyors :	
Screw / Apron / Belt / Chain	1.25
Bucket / Rotary / Lifts	1.50
Reciprocating	3.00
Hoists:	
Medium duty	2.50
Heavy duty	3.00
Elevators :	
Centrifugal and gravity disc	1.25
DREDGERS	2.00
FOOD INDUSTRY	
Packaging machines and fillers	1.25
Kneading machines	1.50
Cane crushers	1.50
Cane cutters	1.50
Cane mills	2.00
Sugar beet cutters	1.50
Sugar beet washing machines	1.50
GENERATORS	
Even load	1.00
Frequency converters	1.50
Welding generators	2.00

MACHINE TOOLS	
Main Drives	2.00
Auxiliary and transverse drives	1.50
METAL WORKING	
Presses / Hammers	2.00
Straighteners	2.00
Bending machines / Shears	1.50
Punching machines	2.00
MARINE APLICATIONS	2.25 - 2.50
MINING AND STONES	
Crushers	2.50
Mills	2.50
Mine ventilators	2.00
Vibrators	1.50
OIL INDUSTRY	
Pipeline pumps	1.50
Rotary drilling equipment	2.00
PAPER INDUSTRY	
Calendars	2.00
Couches	2.00
Drying cylinders	2.25
Pulpers	2.00
Pulp grinders	2.00
Suction rolls	2.00
Wet presses	2.00
Reels	2.00
Agitators	2.00
PLASTIC INDUSTRY	
Calendars , Crushers , Mixers.	1.75
PUMPS	
Centrifugal , General Feed or Boiler Feed	1.00
Centrifugal , Slurry	1.50
Centrifugal , Dredge	2.00
Rotary / Gear / Lobe or Vane	1.50
Reciprocating :	
1 cylinder	3.00
2 cylinder , single acting	2.00
2 cylinders , double acting	1.75
3 cylinders or more	1.50

ROLLING MILLS	
Billet shears	2.50
Chain transfers	1.50
Cold rolling mills	2.00
Continuous casting plants	2.50
Cooling beds	1.50
Cropping shears	2.00
Cross transfers	1.50
Descaling machines	2.00
Heavy and medium duty mills	3.00
Ingot and blooming mills	2.50
Ingot handling machinery	2.50
Ingot pushers	2.50
Manipulators	2.00
Plate shears	2.00
Roller adjustment drives	1.50
Roller straighteners	1.50
Roller tables (heavy)	2.50
Roller tables (light)	1.50
Sheet mills	2.50
Trimming shears	1.50
Tube and welding machines	2.00
Winding machines	1.50
Wire drawing benches	1.50
RUBBER INDUSTRY	
Extruder	1.75
Calendar	2.00
Mixing mill / Refiner / Crusher	2.50
STEEL PLANTS	
Blast furnace blowers	1.50
Converters	2.50
Inclined blast furnace elev.	2.00
Crushers	2.00
TEXTILE MACHINES	
Printing and drying machines	1.50
Tanning vats	1.50
Calendars	1.50
Looms	1.50
WATER AND WASTE INDUSTRY	
Aerators, Screw pumps, Screens	1.50
WOOD WORKING MACHINERY	
Trimmers, Barkers, Saws, Planes	2.00

Note 1: Check local and industrial safety codes.
 Note 2: The factors in Table 1 are for general guidance and can be modified by customers specialist knowledge of their own equipment.

Table 4

Driven Equipment	SF _D
BLOWERS , FANS	
Multi-cylinder engine	
8 or more	0.50
6	1.00
4 or 5	1.50
Less than 4	Call Unlaub
Variable speed motors	0.80
Electric motors ¹ and turbines	0.00

¹ except variable speed motors

Please consult Unlaub if quick axial excitations are foreseeable either on the driving or driven side

SELECTION / RATINGS DATA

Table 5 Ratings (Imperial Units)

Coupling Size	Max Bore		Torque			Max RPM		Axial Misalignment (in) (4)	Angular Misalignment (5)	Weight (lbs) (3)
	Standard Hub (in)	Large Hub (in)	HP/100	Nominal (in.-lbs.)	Max. (in.-lbs.)	Standard (1)	Balanced (2)			
115	2.047	2.953	8.07	5089	10178	7200	18000	0.083	1.5°	12
139	2.638	3.543	15.44	9736	19471	5840	14600	0.102		22
165	3.150	4.134	28.09	17701	35403	4920	12300	0.122		40
193	3.740	4.921	46.34	29207	58415	4200	10500	0.146		62
210	4.016	5.315	64.60	40713	81427	3840	9600	0.150	1°	82

NOTES:

1. Standard U-DISC couplings will meet the maximum speed listed in the "Standard" column.
2. Speed capabilities listed in the "Balanced" column require special balancing by U-DISC.
3. Weight of complete coupling at maximum bores.
4. Axial misalignment for two disc packs.
5. Angular misalignment for one disc pack.

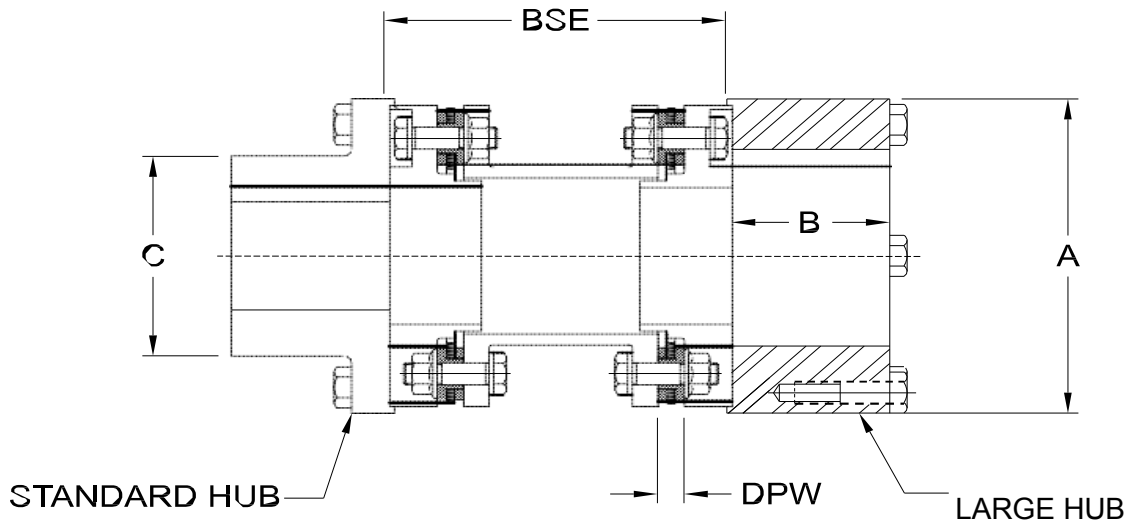

Table 6 Dimensions (Inch / mm)

Coupling Size	A	B	C	DPW
	Inch / (mm)	Inch / (mm)	Inch / (mm)	Inch / (mm)
115	4.53 / (115)	1.97 / (50)	2.87 / (73)	0.331 / (8.40)
139	5.47 / (139)	2.36 / (60)	3.74 / (95)	0.331 / (8.40)
165	6.50 / (165)	2.76 / (70)	4.41 / (112)	0.441 / (11.20)
193	7.60 / (193)	3.15 / (80)	5.28 / (134)	0.551 / (14.00)
210	8.27 / (210)	3.54 / (90)	5.67 / (144)	0.610 / (15.50)

NOMENCLATURE / PART NUMBERS

U-DISC COUPLINGS CONSIST OF: TWO (2) HUBS (STANDARD OR LARGE) AND ONE (1) SPACER CENTER ASSEMBLY

U-DISC Coupling Hub Nomenclature

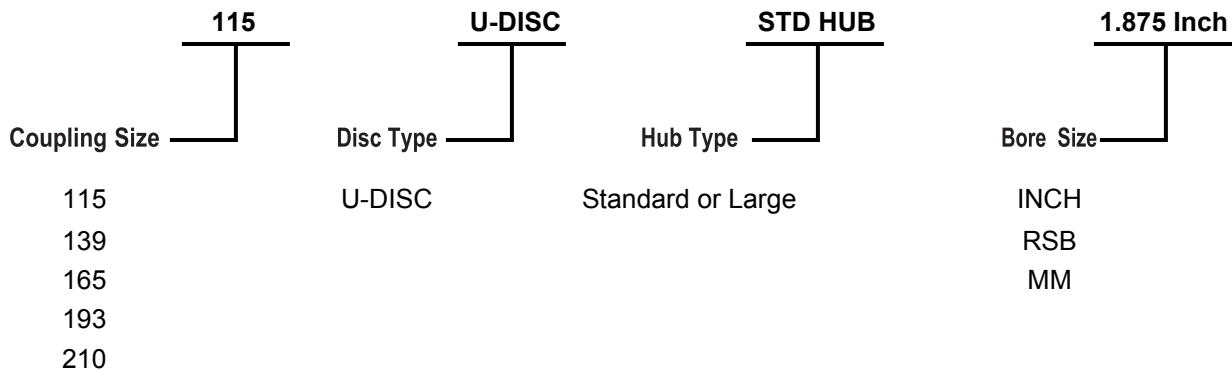

U-DISC Coupling Center Assembly Nomenclature

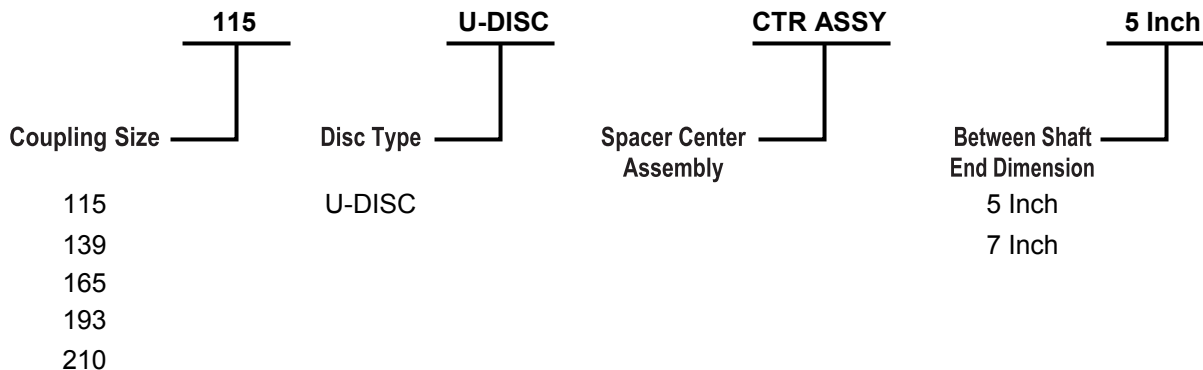

CENTER ASSEMBLY PART NUMBERS

Inch BSE (in)	Size 115	Size 139	Size 165	Size 193	Size 210
5	A59138461	A59138465	A59138468	A59138471	A59138475
7	A59138462	A59138466	A59138469	A59138472	A59138476

U-DISC COUPLING INCH BORE HUB PART NUMBERS

U-DISC COUPLINGS CONSIST OF: TWO (2) HUBS (STANDARD OR LARGE) AND ONE (1) SPACER CENTER ASSEMBLY

Item numbers listed below are standard stocked items available for SAME DAY SHIPPING SERVICE!

Hub Style	Bore Size (Inch)	Unlaub Part #	Description
115	1-7/8	A59395762	115 U-DISC STD HUB 1.875 CL SS .500" KW
	2 SP KW	A59395761	115 U-DISC LG HUB 2.000 CL SS .625" NON-STANDARD KW
	2-1/8	A59395486	115 U-DISC LG HUB 2.125 CL SS .500" KW
	2-3/8	A59395539	115 U-DISC LG HUB 2.375 CL SS .625" KW
	RSB	A59138023	115 U-DISC STD HUB RSB
	RSB	A59138046	115 U-DISC LG HUB RSB
Hub Style	Bore Size (Inch)	Unlaub Part #	Description
139	1-5/8	A59395489	139 U-DISC STD HUB 1.625 CL SS .375" KW
	1-5/8 SP KW	A59395769	139 U-DISC STD HUB 1.625 CL SS .500" NON-STANDARD KW
	2 SP KW	A59395758	139 U-DISC STD HUB 2.000 CL SS .625" NON-STANDARD KW
	2-3/8	A59395509	139 U-DISC STD HUB 2.375 CL SS .625" KW
	2-5/8	A59395510	139 U-DISC STD HUB 2.625 CL SS .625" KW
	RSB	A59138051	139 U-DISC STD HUB RSB
Hub Style	Bore Size (Inch)	Unlaub Part #	Description
165	1-5/8 SP KW	A59395218	165 U-DISC STD HUB 1.625 CL SS .500" NON-STANDARD KW
	1-7/8	A59395219	165 U-DISC STD HUB 1.875 CL SS .500" KW
	2 SP KW	A59395770	165 U-DISC STD HUB 2.000 CL SS .625" NON-STANDARD KW
	2-3/8	A59395220	165 U-DISC STD HUB 2.375 CL SS .625" KW
	2-5/8	A59395300	165 U-DISC STD HUB 2.625 CL SS .625" KW
	RSB	A59138081	165 U-DISC STD HUB RSB
Hub Style	Bore Size (Inch)	Unlaub Part #	Description
193	1-5/8 SP KW	A59395261	193 U-DISC STD HUB 1.625 CL SS .500" NON-STANDARD KW
	2 SP KW	A59395771	165 U-DISC STD HUB 2.000 CL SS .625" NON-STANDARD KW
	2-3/8	A59395600	193 U-DISC STD HUB 2.375 CL SS .625" KW
	2-1/2	A59395542	193 U-DISC STD HUB 2.500 CL SS .625" KW
	2-5/8	A59395543	193 U-DISC STD HUB 2.625 CL SS .625" KW
	2-7/8	A59395297	193 U-DISC STD HUB 2.875 CL SS .750" KW
	RSB	A59138106	193 U-DISC STD HUB RSB

- Additional bore sizes or non-standard keyways available upon request.
- Item numbers listed below with asterisk (*) are stocked items.
- Please request quote for non stocked items to verify lead time.

Size Inch Bore (in)	115		139	165	193	210
	Standard Hub	Large Hub	Standard Hub	Standard Hub	Standard Hub	Standard Hub
Reborable	A59138023*	A59138046*	A59138051*	A59138081*	A59138106*	A59138130
1/2						
5/8						
3/4						
7/8						
15/16	A59115015					
1	A59115100		A59139100	A59165100		
1 1/8	A59115102		A59139102	A59165102		
1 3/16	A59115103		A59139103	A59165103		
1 1/4	A59115104		A59139104	A59165104	A59193104	A59210104
1 3/8	A59115106		A59139106	A59165106	A59193106	A59210106
1 7/16	A59115107		A59139107	A59165107	A59193107	A59210107
1 1/2	A59115108		A59139108	A59165108	A59193108	A59210108
1 5/8	A59115110		A59395489*	A59395421*	A59395298*	A59210110
1 11/16	A59115111		A59139111	A59165111	A59193111	A59210111
1 3/4	A59115112		A59139112	A59165112	A59193112	A59210112
1 7/8	A59395762*		A59139114	A59395219*	A59193114	A59210114
1 15/16	A59115115		A59139115	A59165115	A59193115	A59210115
2		A59115200	A59139200	A59165200	A59193200	A59210200
2 1/8		A59395486*	A59139202	A59395223	A59193202	A59210202
2 3/16		A59115203	A59139203	A59165203	A59193203	A59210203
2 1/4		A59115204	A59139204	A59165204	A59193204	A59210204
2 3/8		A59395539*	A59395509*	A59395220*	A59395600*	A59395222
2 7/16		A59115207	A59139207	A59165207	A59193207	A59210207
2 1/2		A59115208	A59395899	A59165208	A59395542*	A59210208
2 5/8		A59115210	A59395510*	A59395300*	A59395543*	A59210210
2 11/16		A59115211	A59139211	A59165211	A59193211	A59210211
2 3/4		A59115212		A59165212	A59193212	A59210212
2 7/8		A59115214		A59395541	A59395297*	A59210214
2 15/16				A59165215	A59193215	A59210215
3				A59165300	A59193300	A59210300
3 1/8				A59165302	A59193302	A59210302
3 1/4					A59193304	A59210304
3 3/8					A59193306	A59210306
3 7/16					A59193307	A59210307
3 1/2					A59193308	A59210308
3 5/8					A59193310	A59210310
3 3/4					A59193312	A59210312
3 7/8						A59210314
3 15/16						A59210315
4						A59210400
4 3/8						
4 3/4						

**INFINITE LIFE
IMPROVED RELIABILITY
REDUCED DOWNTIME**



**MAXIMIZED UPTIME
MINIMIZED MAINTENANCE
SAME DAY SHIPPING**

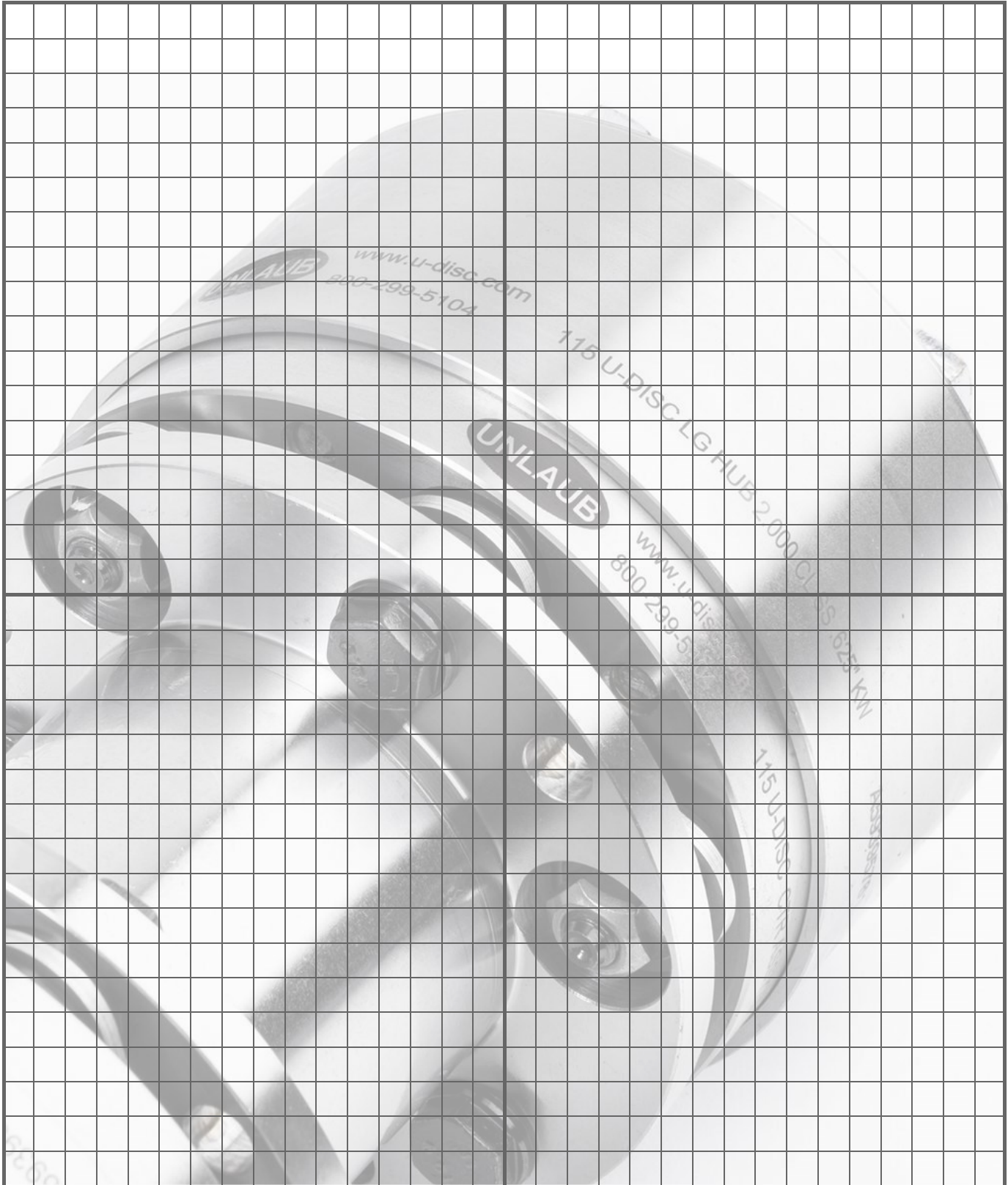

**INFINITE LIFE
IMPROVED RELIABILITY
REDUCED DOWNTIME**



**MAXIMIZED UPTIME
MINIMIZED MAINTENANCE
SAME DAY SHIPPING**

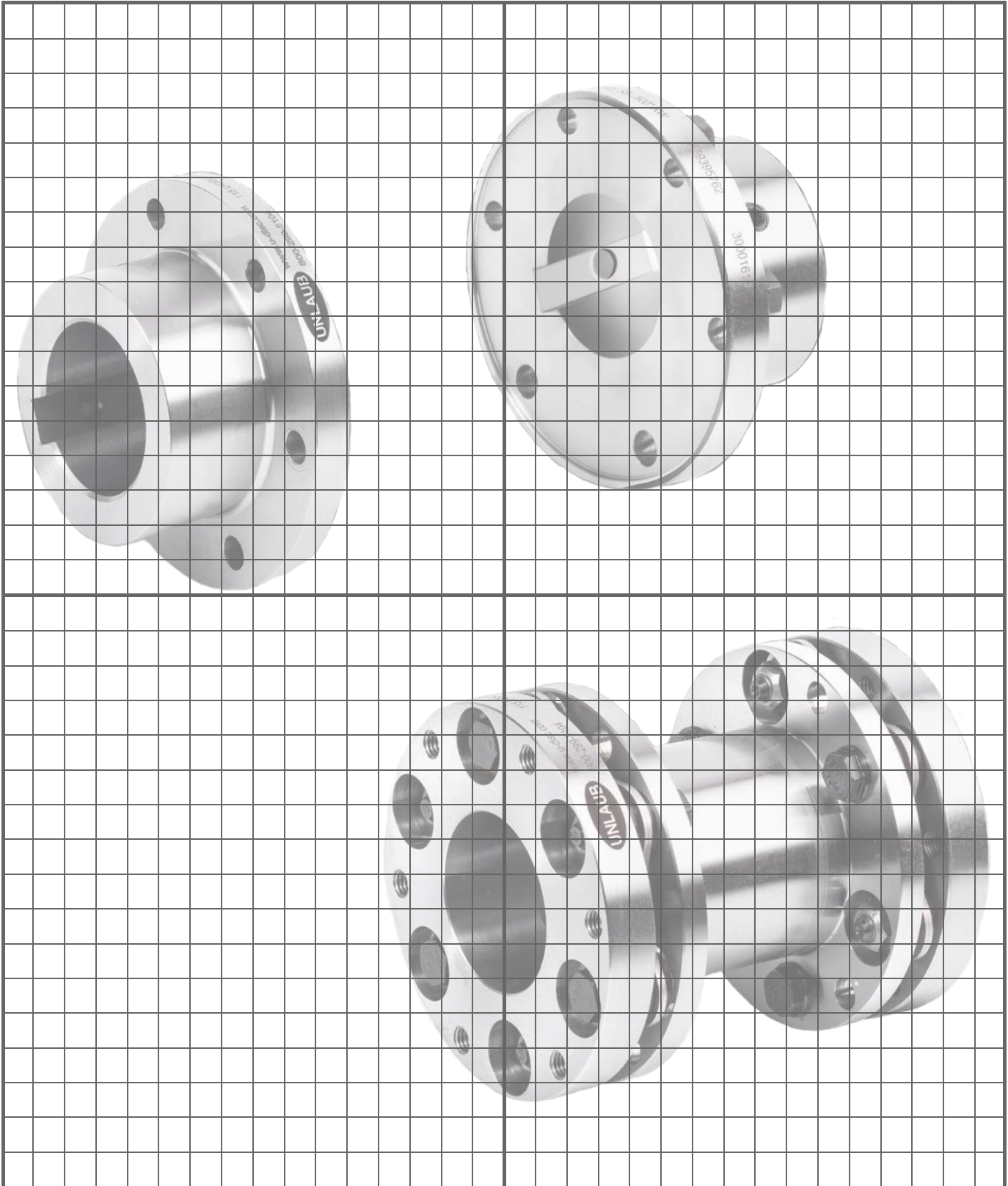



SAME DAY SHIPPING SERVICE

THE UNLAUB COMPANY
1722 E. King Place
Tulsa, OK 74110
Toll Free (800) 299-5104
www.unlaub.com

U-DISC.COM

CHANNEL BEARING CO.
118 S. Walter Street
Pasadena, TX 77506
Phone (713) 477-1404
www.unlaub.com